

RAPTOR



RAPTOR



**8KW High Head De-Watering
Submersible Pump.**



5 Ernest Clark Road,
Canning Vale WA 6155
Telephone: 61 8 9256 3192
Facsimile: 61 8 9256 3867
Email: sales@pumpeng.com.au
Website: www.pumpeng.com.au

Distributed by:

Developed in consultation with the Australian Mining Industry and
manufactured by PumpEng® for the Australian Mining Industry

www.pumpeng.com.au

DESIGN MANDATE

PumpEng® through consultation with the Australian Mining Industry now manufactures a Submersible De-watering Pump which encompasses many design features as specifically requested by end users within the Australian mining Industry. The design criteria for the Raptor pump was determined via direct feedback from end users within the Australian mining industry. PumpEng® is proud to deliver the **Raptor Submersible Dewatering Pump**.

DEVELOPED WITH THE AUSTRALIAN MINING INDUSTRY FOR THE CONDITIONS ENCOUNTERED WITHIN THE AUSTRALIAN MINING INDUSTRY

Why Has PumpEng® Manufactured This Pump.

The Australian pump market place is dominated by pumps, which are manufactured overseas. Europe is home to many of these manufacturers & the pumps are mass-produced in enormous manufacturing facilities to achieve significant savings through economies of scale.

The result is a product, which can be sold economically worldwide. However, to achieve these economies of scale savings, the product must be of a standard type design. Given the sizes of the European & North American markets, many product designs are targeted at these two market places.

Below is a chart developed with information obtained from the ITT Flygt Sustainability report 1999. The company is one of the largest pump manufacturers in the world. The report states the following:

- Mining is 5.9% of the Worldwide Customer Base
- Asia Pacific is 8.5% of Worldwide Turnover

By presuming that mining is 5.9% (this figure could vary region by region) of the Asia Pacific market, then it can be estimated that the **Asia Pacific region's contribution from mining only to the organisations worldwide sales is only 0.5%. Australia as an individual Nation would obviously contribute less than the combined Asia Pacific Region.**

Asia Pacific Market Share to Flygt Worldwide Sales

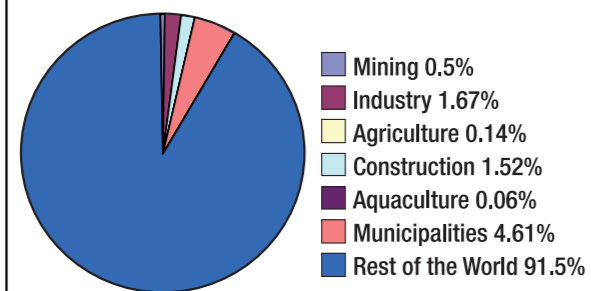

The above figures are shown as a typical indication of the significance of the Australian market to the world's largest pump manufacturers.

As Australian pump users we are sometimes disadvantaged by our minimal demand for & usage of imported product. The result is that our request for product design changes may not be actioned because our percentage of market share is insignificant. Consequently we must keep using the product we are given even though it may not necessarily suit harsh Australian conditions.

As an Australian Company PumpEng® seeks to break the above "Take what your given" design & manufacturing philosophy adopted by many large internationally owned pump manufacturers. We see our Mission as being the supply of products **"Made by Australians to suit Australian mining Conditions"**

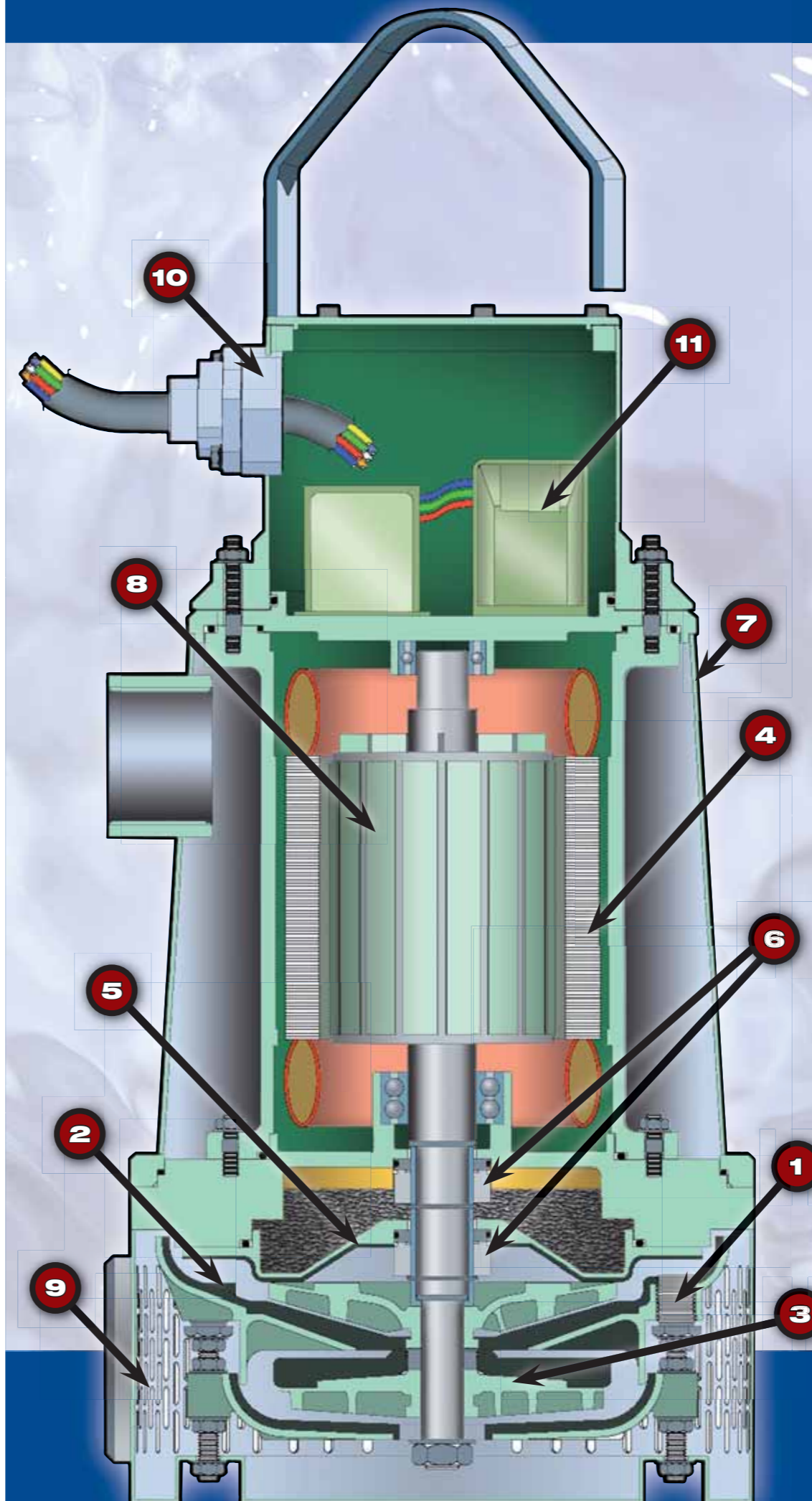

Raptor Design Features

- 1) Patented Shimless Diffuser.** Hydraulic efficiency is quickly & easily maintained via externally adjustable diffuser nuts.
- 2) Super Abrasive Resistant Polyurethane.** Main wear components are lined with a unique urethane especially formulated to suit Australian mining conditions.
- 3) Patented Impeller.** Incorporating a rear shroud to minimize the effect of wear, maintain high operating heads & reduce breakage of vane tips. Rear pump out vanes to effectively remove solids from the rear of the Impeller & a replaceable neck bush to minimize the replacement of the entire Impeller when wear occurs. Upper & lower Impellers are manufactured in 27% Chrome iron
- 4) Motor Windings.** Available as standard in 415v & 1000v, 3 phase, 50 cycle. All windings are supplied with class H insulation.
- 5) Oil Housing.** Fitted with large tapered seal cavity incorporating Vortex Braking Ribs to keep solids & grit away from the seal faces thereby preventing premature wear.
- 6) Dual Mechanical Seals.** Upper & lower mechanical seal are fitted with Solid Tungsten carbide wearing faces to prevent wear. Seal lubrication is provided by an oil reservoir located between the Oil Housing & Bearing Housing lower. Optional water in oil sensor is available upon request.
- 7) Specialty Materials.** Stainless Steel Outer Casing as standard. Impellers are also available in CD4MCU Duplex Stainless steel. Stator Casing, Bearing Housing & Strainer are also available in 316SS. A complete 316ss corrosion resistant pump will be released onto the market in 2006.
- 8) Maintenance Friendly Rotor.** Rotor design allows replacement shafts to be easily fitted thus eliminating the costs & inconvenience of refurbishing the shaft. Shaft repair capabilities are further enhanced via a replaceable shaft sleeve fitted underneath the mechanical seals.
- 9) Strainer.** Heavy duty Hot dipped galvanized construction with external reinforcing bars to prevent strainer damage. A bottom suction variant is available for duties where carbon fibre from re-enforced concrete causes clogging problems within the pump.
- 10) Side Entry Lid.** The cable entry unit is situated at the side of the lid to prevent damage to this item when lifting the pump. A removable top cap allows easy access to the cable connections without the requirement of having to remove the entire lid assembly.
- 11) Maintenance Reporting.** Data recorders within the pump log relevant operating parameters which can be downloaded to a computer. This feature allows maintenance staff to be able to investigate abnormal operating parameters with a view to eliminating the offending occurrence.

**Made by Australians
to suit
Australian mining
conditions**